

EUROPEAN STANDARD
NORME EUROPÉENNE
EUROPÄISCHE NORM

FINAL DRAFT
EN 1523

ICS 13.310; 91.060.50

Descriptors : windows, doors, closures, mechanical strength, shock resistance, fire arms, tests, testing conditions, accident prevention

English version

Windows, doors, shutters and blinds - Bullet resistance - Test method

Fenêtres, portes, fermetures et stores - Résistance aux balles - Méthode d'essai Fenster, Türen, Abschlüsse - Durchschußhemmung - Prüfverfahren

This European Standard was approved by CEN on 1998-08-

CEN members are bound to comply with CEN/CENELEC Internal Regulations which stipulate the conditions for giving this European standard the status of a national standard without any alteration.

Up-to-date lists and bibliographical references concerning such national standards may be obtained on application to the Central Secretariat or to any CEN member.

This European Standard exist in three official versions (English, French, German). A version in any other language made by translation under the responsibility of a CEN member into its own language and notified to the Central Secretariat has the same status as the official versions.

CEN members are the national standard bodies of Austria, Belgium, Czech Republik, Denmark, Finland, France, Germany, Greece, Iceland, Ireland, Italy, Luxembourg, Netherlands, Norway, Portugal, Spain, Sweden, Switzerland and United Kingdom.

CEN

European Committee for Standardization
Comité Européen de Normalisation
Europäisches Komitee für Normung

Central Secretariat : rue de Stassart 36, B-1050 Brussels

© 1998 Copyright reserved to all CEN members.

Ref. No. EN 1523:1998 E

Contents

Foreword	3
1 Scope	4
2 Normative references	4
3 Definitions	4
4 Apparatus	6
5 Test specimen	7
6 Procedure	7
7 Interpretation of results	11
8 Test report	11
9 Test report summary	12
Annex A (informative) Operable windows and doors	14
Annex B (informative) Facades and fixed components	15
Annex C (informative) Components	16
Annex D (informative) Folding shutter	17
Annex E (informative) Roller shutters	18

Foreword

This European Standard has been prepared by Technical Committee CEN/TC 33 "Doors, windows, shutters and building hardware", the secretariat of which is held by AFNOR.

This European Standard shall be given the status of a national standard, either by publication of an identical text or by endorsement, at the latest by April 1999, and conflicting national standards shall be withdrawn at the latest by April 1999.

The standard includes five informative annexes illustrating examples of target points and firing directions.

According to the CEN/CENELEC Internal Regulations, the national standards organizations of the following countries are bound to implement this European Standard: Austria, Belgium, Czech Republic, Denmark, Finland, France, Germany, Greece, Iceland, Ireland, Italy, Luxembourg, Netherlands, Norway, Portugal, Spain, Sweden, Switzerland and the United Kingdom.

1 Scope

This European Standard defines a test procedure to permit classification of the bullet resistance of windows, doors, shutters and blinds (complete with their infills).

This European Standard concerns only behavior in respect of the frame of the windows, doors, shutters or blind, their infills and the junctions between the infills and frames.

If the windows and doors are subjected to specific conditions of climate, specific conditions of test may be required.

It does not apply to the testing of glass infills. For the testing of glass infills refer to prEN 1063.

This European Standard gives no information on the behavior of the frame subjected to other types of stresses.

It gives no information on the bullet resistance of the junction between the frame and the wall or other surrounding structure.

Shutters and Blinds must be tested separately and not in conjunction with a window or door, in order to achieve classification in terms of bullet resistance.

NOTE : Care should be taken to ensure that all joints between the surrounding wall and the window, door, shutter or blind will have bullet resistance at least equal to that of the window, door, shutter or blind.

2 Normative references

This European Standard incorporates by dated or undated reference, provisions from other publications. These normative references are cited at the appropriate places in the text and the publications are listed hereafter. For dated references, subsequent amendments to or revisions of any of these publications apply to this European Standard only when incorporated in it by amendment or revision. For undated references the latest edition of the publication referred to applies.

EN 1522	Windows, doors, shutters and blinds - Bullet resistance - Requirements and Classification
prEN 1063	Specification for security glazing - Bullet resistant glazing - Classification and test methods

3 Definitions

For the purpose of this European Standard, the following definitions apply :

3.1 test specimen

Sample prepared for testing.

3.2 perforation

Piercing of a test specimen by a bullet or by bullet fragments, and/or creation of an opening from the attack face to the rear face.

The following are considered to constitute perforation :

- a) passing through the test specimen by the bullet or any part of it ;
- b) splitting of the rear surface of the test specimen by the bullet or part of it, even if the bullet is visibly retained in the rear of the test specimen ;
- c) creation of an opening right through the specimen, even if that opening closes again afterwards.

Perforation has not occurred if none of the above criteria are fulfilled.

3.3 witness foil

Sheet of foil positioned behind the test specimen in order to detect splinters ejected from the rear face of the test specimen by the impact of the bullet and to determine the risks of injury due to the ejection of these splinters.

3.4 splinters collecting box

Receptacle for gathering splinters ejected from the rear face and bullet fragments passing through the test specimen, positioned between the test specimen and the witness foil.

3.5 presence or absence of splinters

Presence of splinters, designated 'S' is considered to be applicable when there is no perforation of the test specimen by the bullet or any part of it, but there is perforation of the witness foil caused by splinters which are ejected from the rear face of the test specimen.

Absence of splinters, designated 'NS' is considered to be applicable in all cases where there is no perforation of the witness foil.

3.6 attack face

The face of a test window, door, shutter or blind designed to face the attack. It corresponds to that face of the installed infill which is intended to fulfill the same function.

3.7 striking distance

The distance between the centres of two target points on the test specimen.

3.8 bullet velocity

The velocity of the bullet measured within 2,5m in front of the attack face of the test specimen.

3.9 test range

The distance between the muzzle of the firearm and the attack face of the test specimen.

3.10 submission document

Mandatory set of documents to be delivered to the testing laboratory with the test specimen.

4 Apparatus

4.1 Test specimen support

The test specimen support shall be rigid enough not to deflect under the effect of impacts to which the test specimen is subjected.

4.2 Witness foil

The witness foil consists of a sheet of aluminium foil 0,02 mm thick weighing 54/m², large enough to detect all splinters that might be ejected from the test specimen and with the edges of the foil mounted rigidly in a frame.

4.3 Splinters collecting box

4.4 Shooting equipment

4.4.1 Ballistic Test Equipment

The test may be conducted using either weapons or proof barrels.

4.4.2 Velocity measuring Device

The bullet velocity has to be measured with a measuring device which offers an accuracy of $\pm 1,0$ metres per second.

4.5 Ammunition

The shots shall be carried out with ammunition corresponding to the required resistance class in Table 1 or 2 of EN 1522.

5 Test specimen

The number and types of test specimens required are determined by the testing laboratory from examination of the drawings of the complete window, door, shutter or blind.

The size of the test specimen(s) shall be agreed between the testing laboratory and the applicant, and shall be such as to allow a valid judgment to be made on the bullet resistance of windows, doors, shutters and blinds of varying dimensions.

Any infill shall be of uniform quality and shall be not smaller than 0,5 m x 0,5 m, except where the size of the complete infill is smaller. The attack face shall be clearly marked.

Infills shall be tested at the same time as the frame, except glass infills previously tested and conforming to prEN 1063. In all cases, the junctions between glass infill and frame shall be tested.

Any glass infill shall have at least the same resistance as that required for the window or door.

The test specimens shall be stored for not less than 24 h in the vertical position at a temperature of $18\text{ °C} \pm 5\text{ °C}$, and shall be maintained at this temperature for the duration of the test.

At the request of the applicant, the testing laboratory shall return the test specimen for retention, adequately and indelibly marked.

6 Procedure

6.1 Installation of test specimen, witness foil and splinters collecting box

Install the test specimen, ensuring :

- a) the correct alignment between all components of the test specimen ;
- b) that the fixings do not create stresses which may influence the test result in the test specimen ;
- c) that the hardware, mechanisms and movable sashes remain operable.

In the case of shutters or blinds, the shutter laths or moving blind must be moved as far as possible to one side so as to obtain the maximum edge clearance (which can occur in use) between the leaf or blind and the fixed frame. This is required to ensure that the maximum edge clearance which can occur in use is fired upon in the test.

Position the witness foil 0,5m behind the test specimen (dimension taken from the mean center line of the test specimen).

Position the splinters collecting box between the test specimen and the witness foil.

6.2 Selection of target areas

The choice of target areas shall depend on the design of the overall window, door, shutter or blind and shall be decided by the testing laboratory on the basis of their analysis of that design whereby they shall have identified the sensitive areas, that is, those where the bullet trajectory can :

a) meet the least resistance ;

or

b) bring about degradation such that it allows access to any opening mechanism which remains in operable condition ;

or

c) cause the unwanted opening of a window, door, shutter or blind.

NOTE : The sensitive areas of the window or door frame and shutter or blind are generally as follows :

1) armoured or reinforced areas (marked 1 and 6 in Annex A, 1 in Annex B, 1, 3 and 4 in Annex C, 1, 6 and 11 in Annex D and 1, 4, 6, 7 and 9 in Annex E).

These are generally made up by reinforcement of the profiles constituting the frames or profiles and laths forming the curtain, the guide rails or the head box for a roller shutter or blind ;

2) junctions between frame and fixed or opening elements, and between infill and frame (marked 2, 3, 4 and 8 in Annex A, 3 in Annex B, 5 in Annex C, 2, 3, 4, 8, 9, 10 and 12 in Annex D and 2, 3, 5 and 8 in Annex E) or any junctions within the test specimen.

These areas correspond in particular to the gaps between frame and opening sash and also to the infill rebate in which the infill is installed ;

3) hardware and construction joints (marked 5 and 7 in Annex A, 2 in Annex B, 2, 6 and 7 in Annex C, 3, 4, 5 and 7 in Annex D and 10 in Annex E). These include for example :

- hinges, latches and operating devices (handles, locks) and their mountings ;

- corner joints or profiles (butt joints or mitered joints) including cleats, screws welds, or other devices which imply some irregularity in the level of resistance.

If different thickness' of reinforcement or different materials are used in different parts of the same frame, each one of these parts shall be tested.

For a door supplied complete with its threshold, if the applicant asks for the threshold to be tested the horizontal gap at floor level shall be subjected to firing. Otherwise the test report summary shall state that this location offers no bullet resistance.

6.3 Arrangement of shots in the selected areas

Each target area must receive three shots as determined in 6.2. Target points shall be clearly marked on the test specimen prior to shooting.

From examination of the drawings of the complete window, door, shutter or blind, the testing laboratory shall determine the target points.

Three circumstances can be identified :

- a) if the area is sufficiently large in proportion to the calibre of the ammunition (for example, on opaque infills or large profiles) the 3 target points shall be chosen on the same element and the striking distances shall be not less than 120 mm (see 1 and 6 in Annex A, 1, 6 and 11 in Annex D and 1, 4, 6, 7 and 9 in Annex E) ;
- b) if the area is reduced to a line (for example butt joints, or junctions between profiles, and sashes or door leaves, and frames and their infills), if the line is long enough, the striking distance between the 3 target points shall be not less than 120 mm (see 3 in Annex A, 2, 3 and 12 in Annex D and 2, 3, 4 and 5 in Annex E).

If not, the striking distances shall be reduced to not less than 3 calibres.

If it is not possible to obtain three shots on the same line, the three shots shall be divided between 2 or 3 identical line on the test specimen (see 5 and 7 in Annex A, 2 in Annex B or 5 and 7 in Annex D).

On previously certified infills installed in the test specimen, the junction between the infill and rebate shall be fired upon with 1 shot at the centre of each of 3 sides of the infill (see 8 in Annex A or 3 in Annex B) ;

- c) if any test location is smaller than 3 calibres in any direction, each similar location shall be tested up to a maximum of 3 shots (see 4 in Annex A, 2, 6 and 7 in Annex C, 4 and 10 in Annex D and 10 in Annex E).

6.4 Number of shots

Three shots shall be fired at each selected target area and in each pre-determined direction and angle in accordance with clause 6.2.

6.5 Firing direction

As appropriate for each target point determined from analysis of the drawings the angle of attack shall be at 90° in relation to the center of the test specimen or the angle that will make the bullet most effective. the target points and the directions of firing shall be shown on the drawings attached to the test report (see clause 8).

The selected angles of attack shall take into consideration the various weak points such as :

- a) joints and intersections of joints ;
- b) meeting edges of sashes ;

- c) overlapping edges of profiles ;
- d) junctions between frames and infills ;
- e) butt joints and mitres.

6.6 Test range

The test range measured from the muzzle to the target point shall be in accordance with the relevant Table of EN 1522.

Nevertheless, when a shot is to be fired at a single point [see 6.3 (c)], the test range may be reduced to allow the correct firing accuracy.

6.7 Firing accuracy

The permissible distance between the point of impact of a bullet and the target point shall be as follows :

- a) when the resistance of the relevant area is identical at any point on the test specimen : 10 mm in any direction ;
- b) when the resistance of the relevant area is identical along a given line : 10 mm along this line, and 5 mm perpendicular to this line ;
- c) when the resistance of the relevant area varies from point to point : 5 mm in any direction.

6.8 Velocity

6.8.1 Bullet velocity

The bullet velocity shall comply with that given in the relevant Table of EN 1522.

Nevertheless, when a shot is to be fired at a single point [see 6.3 (c)], the test range may be reduced to allow the correct firing accuracy. In this case it may not be possible to measure the velocity of the bullet.

6.8.2 Velocity outside range

If during the test a bullet's velocity is recorded as being outside the specified range the shot shall be repeated only in the event of :

- a) a lower velocity with no perforation ; or
- b) a higher velocity, with perforation of the test specimen.

6.9 Examination after firing

After each shot, the rear face of the test specimen shall be examined to determine whether perforation has occurred. The splinter collecting box shall be examined for the presence of splinters. The witness foil shall be examined for evidence of splinters ejected from the rear face of the test specimen.

After each shot the splinter collecting box shall be cleaned out and the witness foil changed if perforated.

6.10 Repeated shot

If the results do not permit an unambiguous interpretation, the laboratory may repeat the shot on the same test specimen or ask for a new test specimen.

If a shot needs to be repeated, the repeated shot shall be fired at a similar location on the test specimen not affected by the disregarded shot.

7 Interpretation of results

The test is considered to be successful even if, after the test, opening mechanisms are no longer operable and even if specified levels of performance in respects other than safety, such as air permeability, watertightness or wind resistance, cannot be maintained. It is necessary, however, that any opening elements remain in the closed position.

When there is no perforation of the test specimen but there is perforation of the witness foil by splinters, the test result shall be classified as 'S' (with splinters). If there is evidence of splinters having perforated the witness foil, the testing laboratory must examine and determine the nature of any fragments to ensure that no part of the bullet has penetrated the test specimen.

In all cases where there is no perforation of the witness foil, the test result shall be classified as 'NS' (no splinter).

The result of a test which has been carried out on a full window, door, shutter or blind is only representative of that window, door, shutter and blind type. If in the future changes are made in the design of the window, door, shutter or blind, the testing laboratory will judge whether the same test report can be extended to that modification or whether a supplementary test is required. In that case, this will be indicated on the new test report.

8 Test report

The test report issued to the applicant by the testing laboratory shall state as a minimum :

- a) the identity of the applicant ;
- b) the manufacturer's reference and trade description of the window, door, shutter or blind ;
- c) a detailed description of the constituent parts including materials, joints, reinforcement, hardware, accessories etc. which have been submitted by the applicant.

NOTE : If the applicant wishes, for certain specific bullet resistant materials, the report may indicate that the specifications of those materials have been declared confidentially by the applicant and recorded by the testing authority but have not been described in the report ;

d) drawings supplied by the applicant showing all relevant details of the test specimen to full scale ;

e) the reference of the european Standard ; EN 1523:1998 ;

f) the firing conditions :

- the ambient temperature or specific climatic conditions if there are any ;
- the locations of the points of impact ;
- the angles of attack ;
- the attack face.

The test report shall show these last three points on drawings of the test specimen ;

g) the types of firearms or other equipment equivalent to firearms used, in accordance with Table 1 or 2 of EN 1522 ;

h) the ammunition appropriate to the relevant Class of Table 1 and 2 of EN 1522 ;

i) firing distance if different to those given in Table 1 or 2 of EN 1522 (see 6.8.1) ;

j) the bullet velocity of each shot or when the velocity could not be measured (see 6.8.1), mention this ;

k) the result of each shot with corresponding observations regarding perforation and splintering

l) any observations concerning particular phenomena directly related to the behavior of the test specimen ;

m) the date(s) on which the test was performed ;

n) the test report shall be given a reference number ;

o) the relevant classification obtained in accordance with EN 1522.

9 Test report summary

The testing laboratory where authorized shall be allowed to issue a test report summary to enable the applicant to make trade use of the results obtained with the test specimen.

The test report summary must state that it is valid only for the individual window, door, shutter or blind type tested, with particular emphasis on the type and orientation of the opening elements (inward opening, outward opening, tilt-and turn, vertical or horizontal sliding etc.).

It shall include :

- the relevant classification obtained in accordance with EN 1522 ;
- the test report reference and date of issue ;
- the identity of the applicant ;
- the manufacturer's reference and stated trade description of the window, door, shutter or blind
- any assessment regarding perforation and splintering ;
- any observations concerning particular phenomena directly related to the behavior of the test specimen.

Annex A (informative)

Operable windows and doors

Target points and firing directions

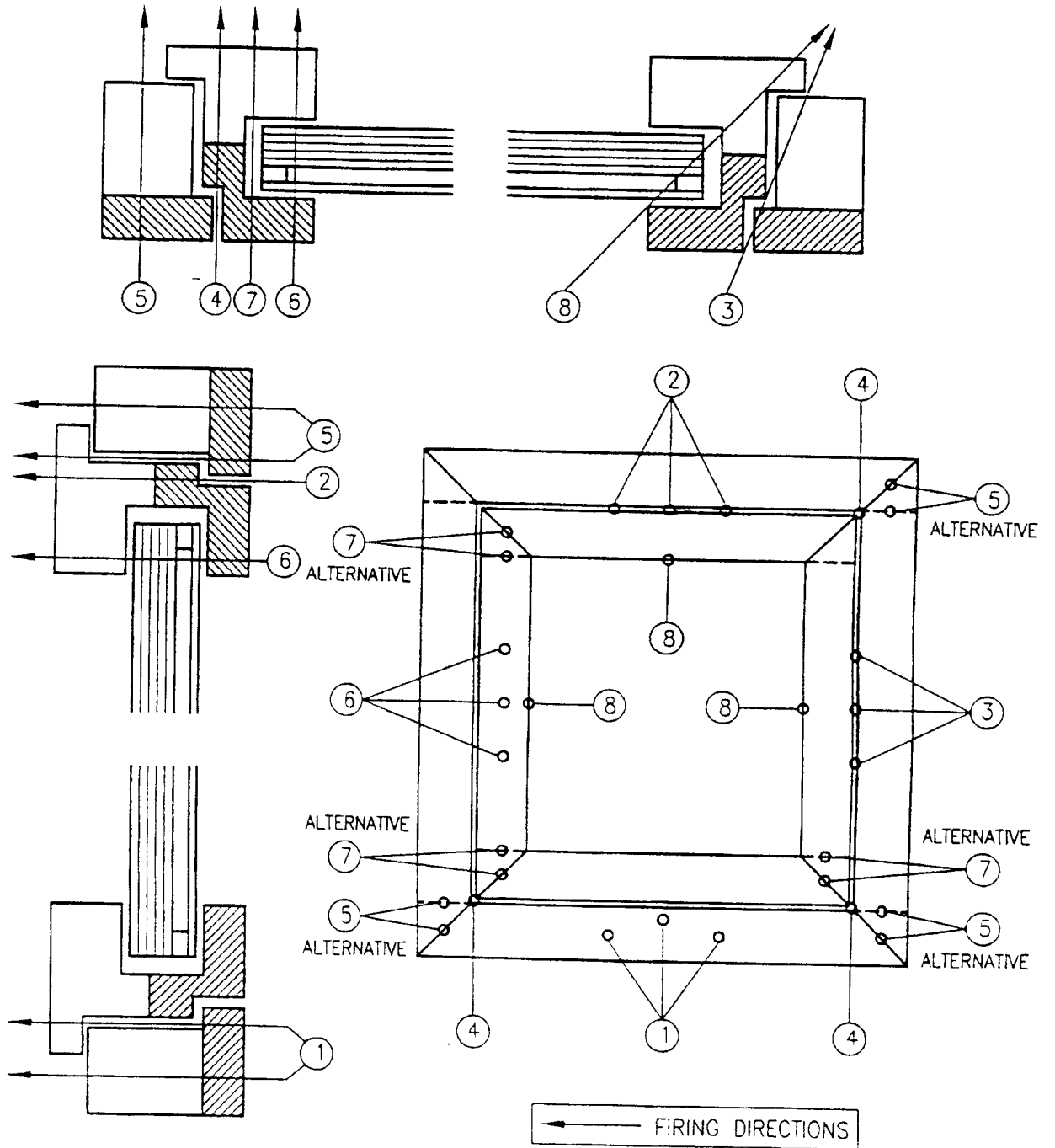

Annex B (informative)

Facades and fixed components

Target points and firing directions

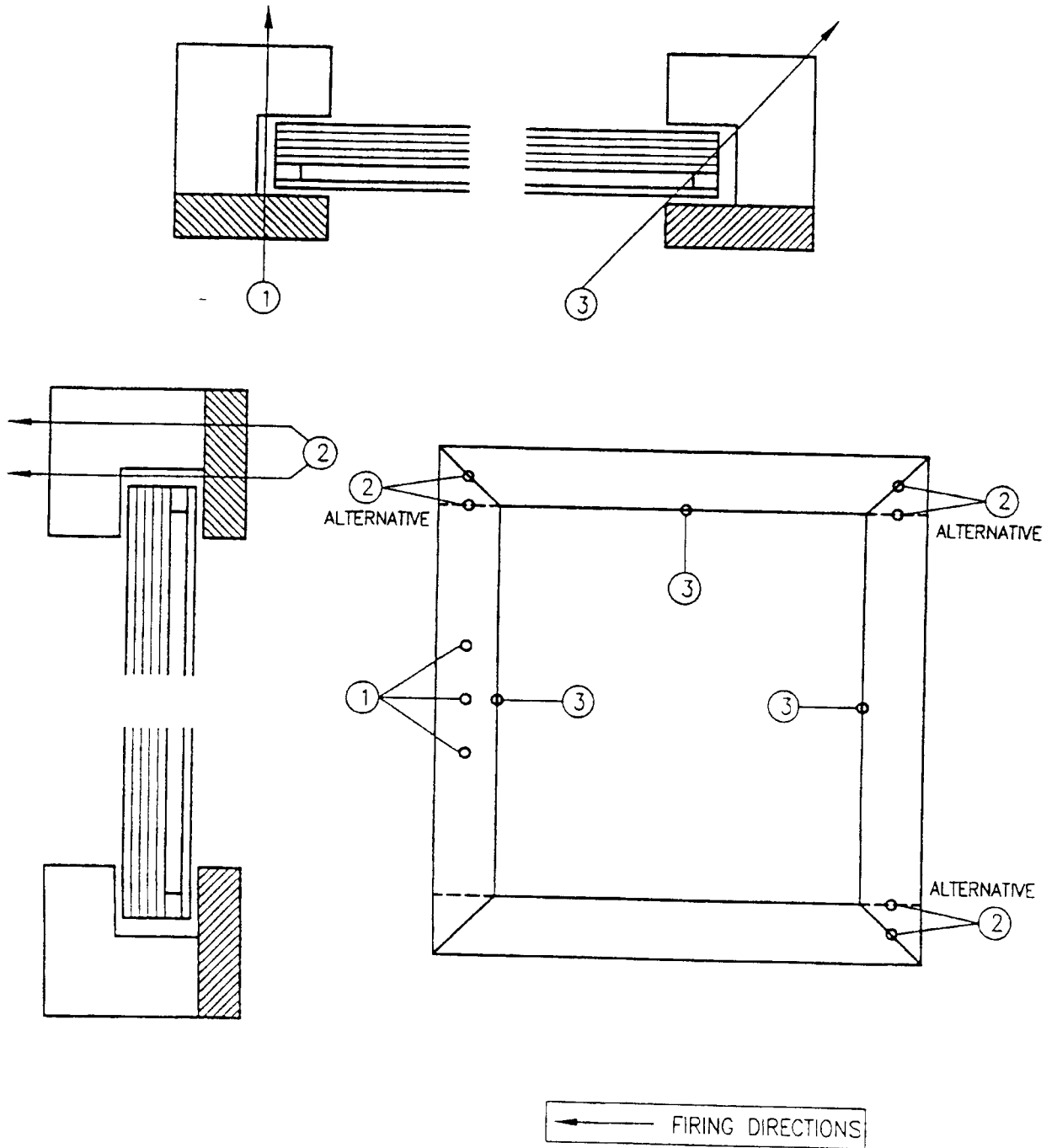

Annex C (informative)

Components

Target points and firing directions

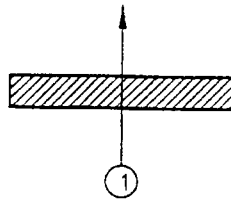
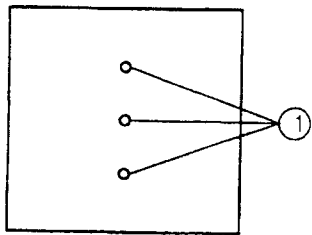

PLATES, PANELS

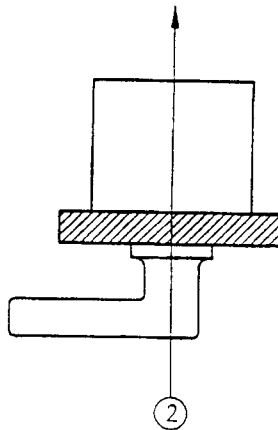
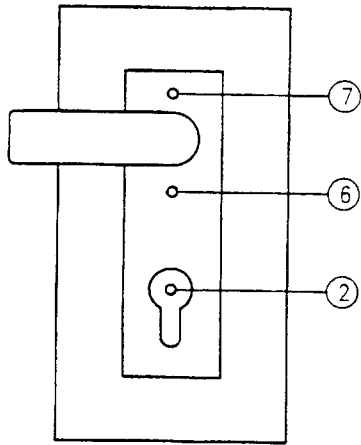

FITTINGS

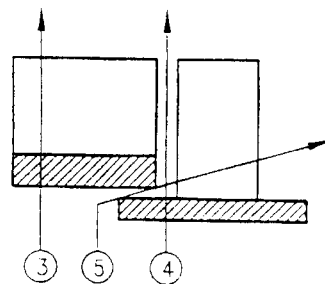
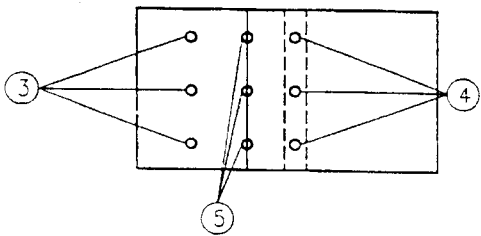

FRAME COMPONENTS

← FIRING DIRECTIONS

Annex D (informative)

Folding shutter

Target points and firing directions

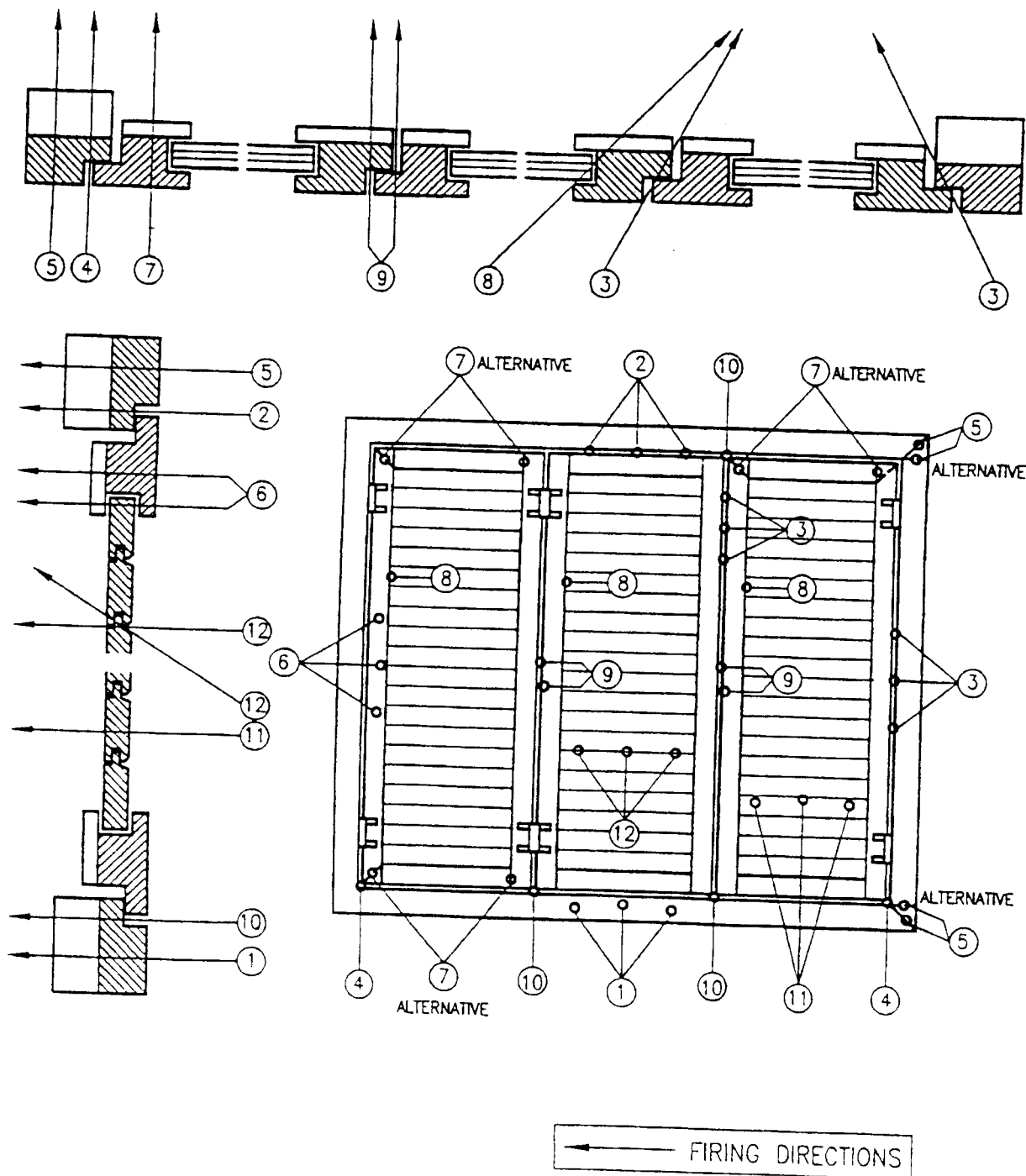

Annex E (informative)

Roller shutters

Target points and firing directions

